

# TOP(A)K(U)S(T)I(K)<sup>®</sup>

A C O U S T I C   S Y S T E M

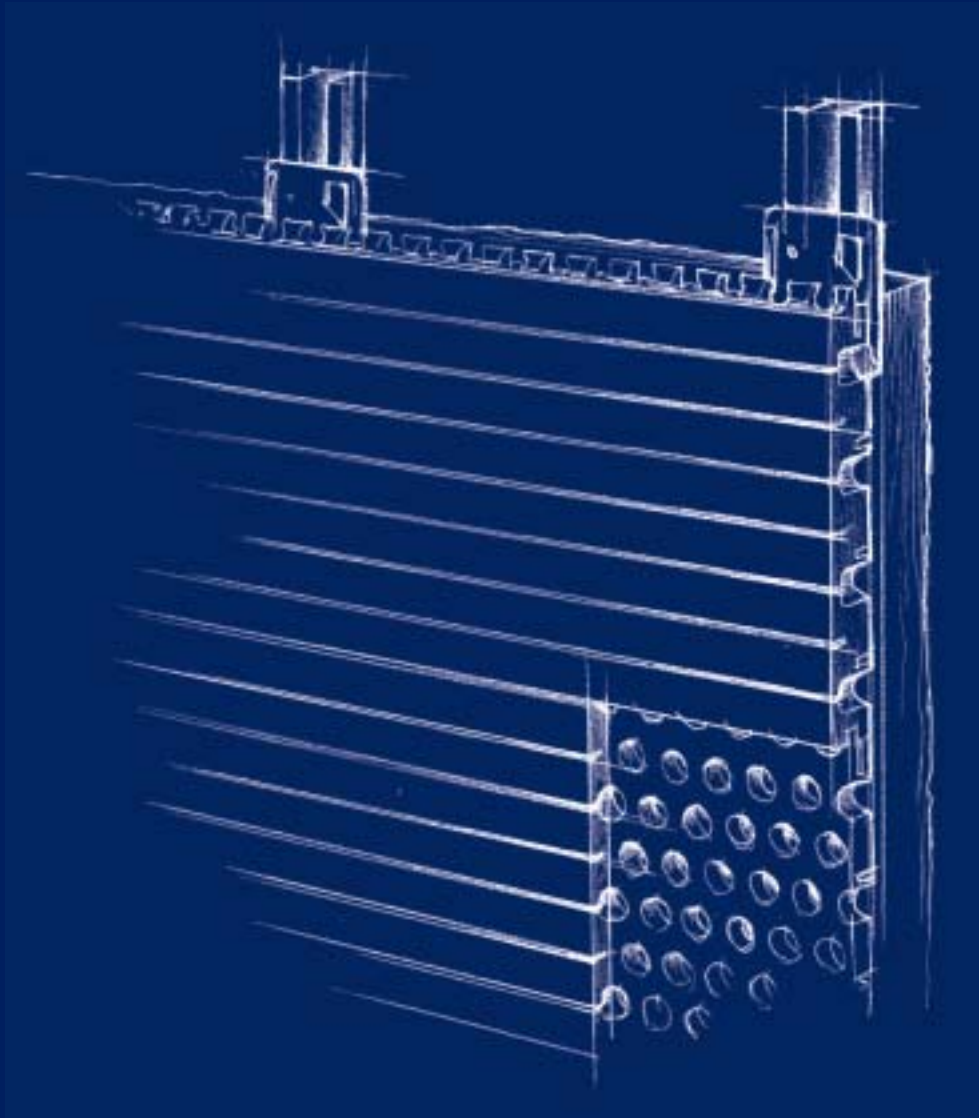

*in opera ...*

**patt**

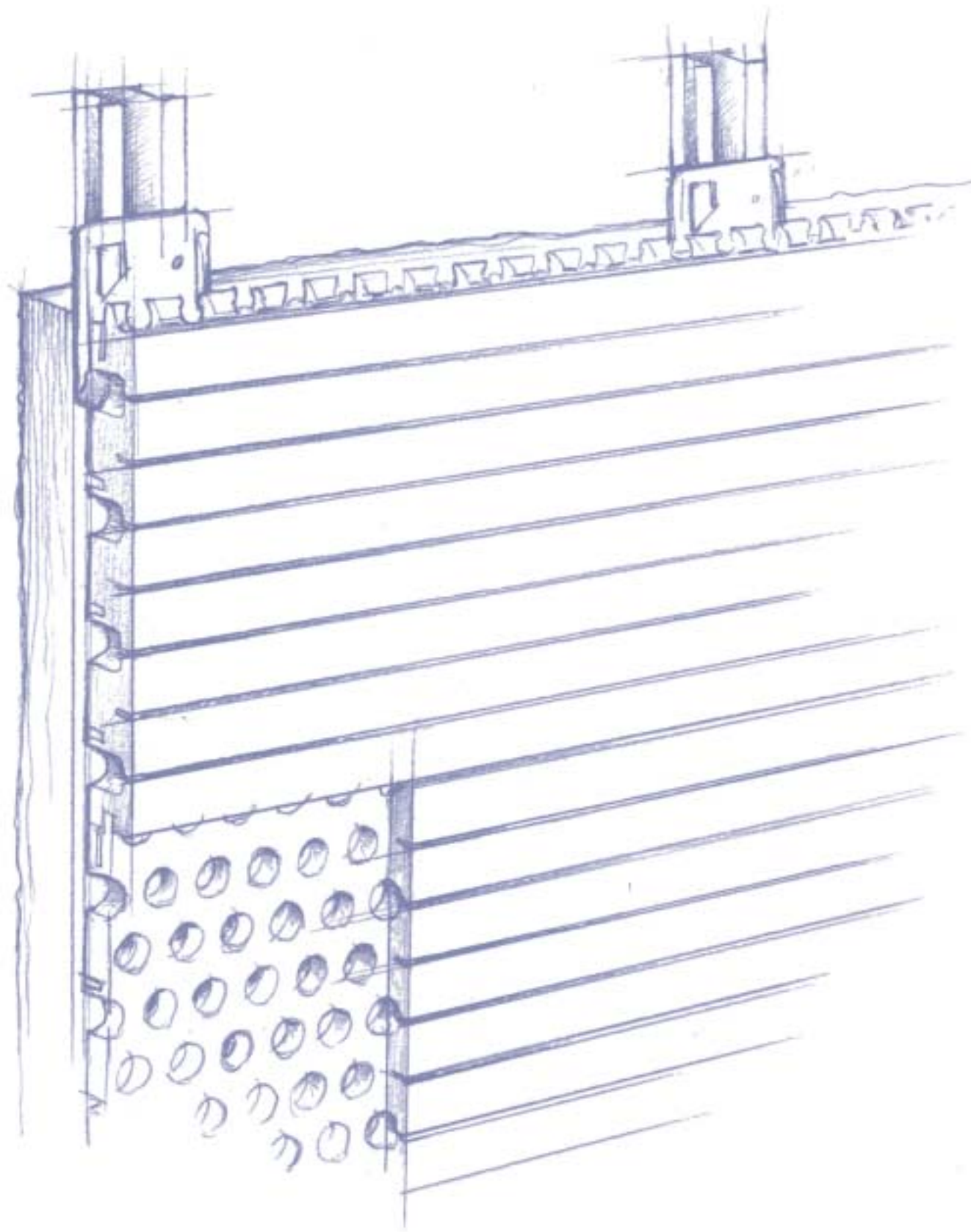

# TOPAKUSTIK®

## **IL PANNELLO FONOASSORBENTE / SOUND-DEADENING PANEL**

### **COS'È**

È l'elemento primario di un sistema che ha la funzione di "catturare" le onde sonore e dissiparle al suo interno. TOPAKUSTIK rappresenta oggi il sistema fonoassorbente più innovativo ed efficiente disponibile sul mercato.

### **A COSA SERVE**

I sistemi fonoassorbenti vengono installati per modificare e migliorare le caratteristiche acustiche di un ambiente, calibrando le prestazioni di fonoassorbenza a seconda della destinazione d'uso. TOPAKUSTIK offre la più ampia gamma di soluzioni per sale pubbliche, impianti sportivi, spazi di lavoro e residenziali. TOPAKUSTIK garantisce inoltre performance evolute unitamente a qualità estetiche insuperabili.

### **WHAT IS IT**

*It's the main component of a system whose function is to "capture" sound waves and dissipate them within itself. TOPAKUSTIK is today the most innovative and efficient sound-deadening system available in the market.*

### **WHAT IS IT USED FOR**

*Sound-deadening systems are installed to modify and improve the acoustic characteristics of an environment, with sound-deadening performance calibrated according to the required use. TOPAKUSTIK offers the widest range of solutions for public halls, sports facilities, work and residential environments. TOPAKUSTIK also guarantees advanced performance combined with exceptional aesthetic qualities.*

**CARATTERISTICHE COMUNI / COMMON CHARACTERISTICS****Materiale e dimensioni**

Materiale di supporto:	MDF 16 mm E1 massa volumica 760 Kg/m <sup>3</sup>  MDF 16 mm FR (ignifugo classe I)
Superficie visibile:	Rivestimento melaminico di nobilitazione Bianco 0118 Acero 1681 Faggio 2018 Alluminio 6265 Ulteriori decorativi secondo mazzetta
Superficie posteriore:	TNT nero, accoppiato
Lunghezza lamelle:	4061 mm
Larghezza lamelle:	128 mm
Tolleranze:	larghezza = 0.1 mm / lunghezza = +/- 2 mm
Lati lunghi:	con unione a incastro maschio - femmina
Lati corti:	taglio di testa a squadra (90°)

**Material and dimensions**

<i>Support material:</i>	<i>MDF 16 mm E1 absolute density 760 Kg/m<sup>3</sup>  MDF 16 mm FR (Class I flame retardant)</i>
<i>Visible surface:</i>	<i>Melamine facing White 0018 Maple 1681 Beech 2018 Aluminium 6265 Other decorative finishes as per sample book</i>
<i>Rear surface:</i>	<i>Black non-woven fabric, bonded</i>
<i>Strip length:</i>	<i>4061 mm</i>
<i>Strip width:</i>	<i>128 mm</i>
<i>Tolerances:</i>	<i>width = 0.1 mm / length = +/- 2 mm</i>
<i>Long edges:</i>	<i>with male-female slotted joint</i>
<i>Short edges:</i>	<i>square cut end (90°)</i>



## TIPOLOGIE / TYPES

### Profili e Lamelle fonoassorbenti TOPAKUSTIK

Le lamelle TOPAKUSTIK sono proposte in diverse tipologie estetiche determinate dalle dimensioni delle fresature e dalla loro distanza reciproca sulla superficie visibile, e dalle distinte geometrie di perforazione del retro. A ciascuna tipologia corrispondono precise caratteristiche di fonoassorbenza.

#### *TOPAKUSTIK rails and sound-deadening strips*

*TOPAKUSTIK strips are available in two types, the appearance of which is determined by the size of the millings and their distance from each other on the visible surface, and by the different drilling geometries on the reverse side. Each type has specific sound-deadening properties.*

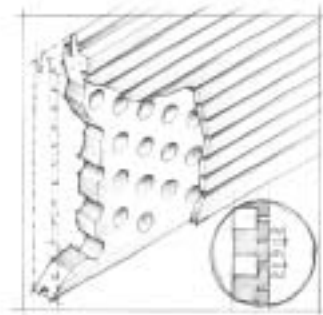

**Tipologia 9/2**  
Perforazione 6%  
*Type 9/2*  
6% drilling

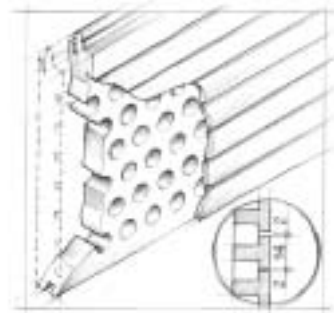

**Tipologia 14/2**  
Perforazione 7%  
*Type 14/2*  
7% drilling

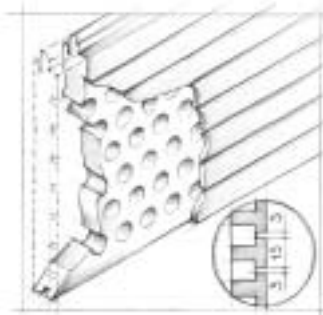

**Tipologia 13/3**  
Perforazione 12%  
*Type 13/3*  
12% drilling

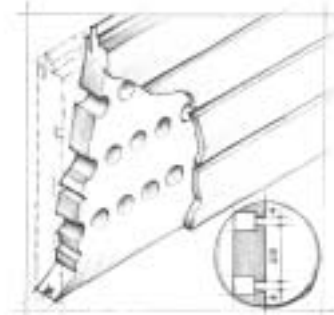

**Tipologia 28/4**  
Perforazione 7.5%  
*Type 28/4*  
7.5% drilling



**TOPAKUSTIK 9/2: grado di fonoassorbenza secondo ISO 354**  
**TOPAKUSTIK 9/2: sound-deadening capacity according to ISO 354**

Materiale testato <i>Material tested</i>	tipologia / <i>type</i> 9/2 M - perforazione / <i>drilling</i> 6% tessuto / <i>fabric</i> SP 60 N	
Misurazione in camera riverberante <i>Measurements</i> <i>in reverberation chamber</i>	riferimento / <i>reference</i> : volume / <i>volume</i> : temperatura / <i>temperature</i> : umidità dell'aria / <i>air humidity</i> : superficie rivestita / <i>area covered</i> :	03.05.1999 214.3 m <sup>3</sup> 20° 55% 12m <sup>2</sup>

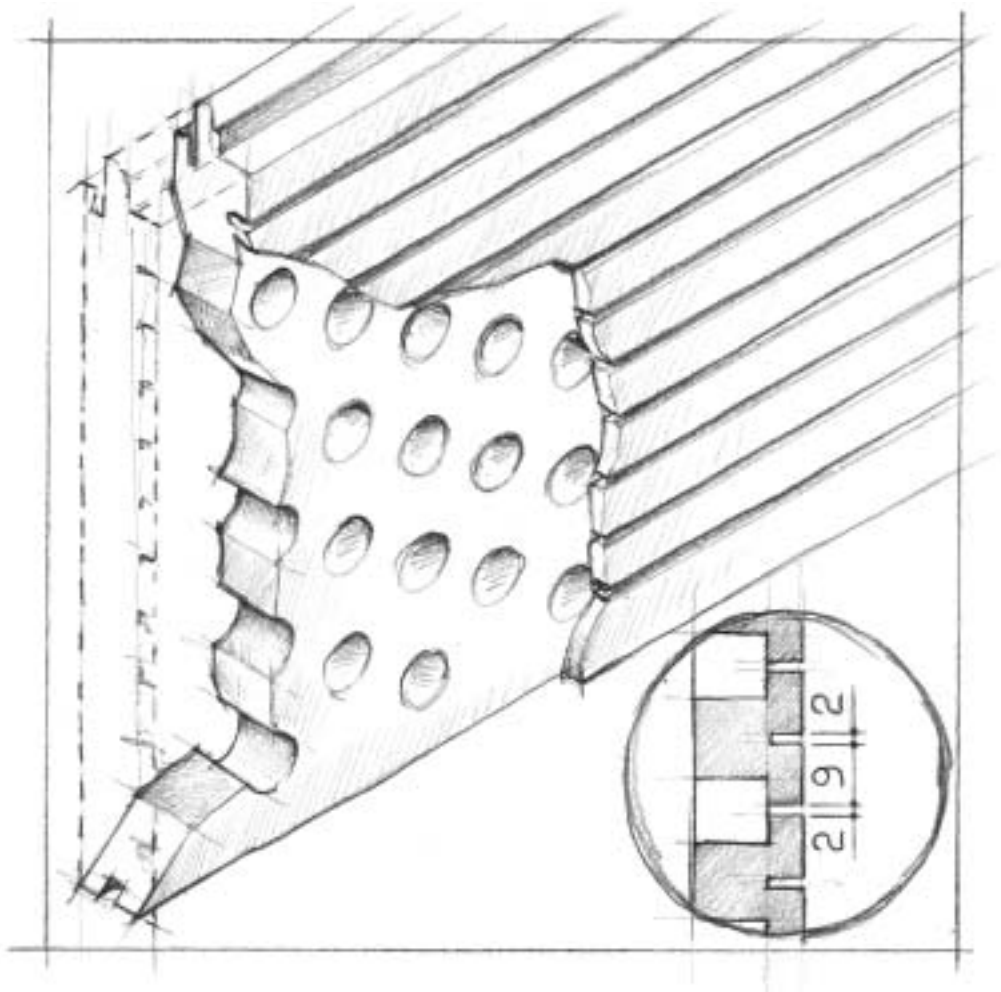

**tipologia 9/2 perforazione 6%**  
**type 9/2 drilling 6%**

**VALORI MEDI DI FONOASSORBENZA / SOUND ABSORPTION AVERAGE VALUES**

Freq. (Hz)	Risultato / Result
100	0.27
125	0.33
160	0.46
200	0.75
250	0.77
315	0.90
400	0.93
500	0.90
630	0.85
800	0.85
1000	0.88
1250	0.86
1600	0.82
2000	0.74
2500	0.64
3150	0.60
4000	0.59
5000	0.57

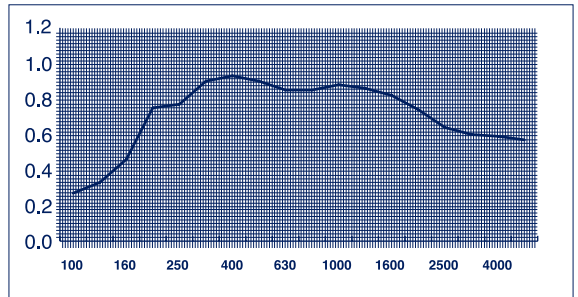
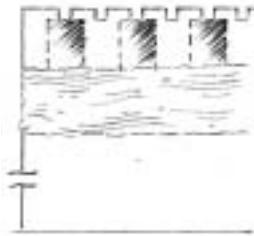

**Spazio vuoto / Free Space 170 mm lana di roccia / Mineral Wool 30 mm**

Basse frequenze / Low frequency (100-315 Hz): 0.58  
 Medie frequenze / Medium frequency (400-1250 Hz): 0.88  
 Alte frequenze / High frequency (1600-5000 Hz): 0.66

Freq. (Hz)	Risultato / Result
100	0.10
125	0.14
160	0.26
200	0.38
250	0.64
315	0.81
400	0.95
500	1.06
630	1.03
800	1.04
1000	1.01
1250	0.86
1600	0.77
2000	0.70
2500	0.63
3150	0.60
4000	0.59
5000	0.56

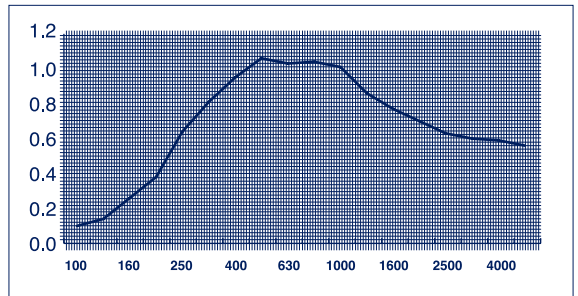
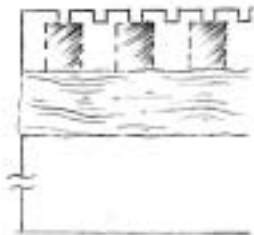

**Spazio vuoto / Free Space 10 mm lana di roccia / Mineral Wool 30 mm**

Basse frequenze / Low frequency (100-315 Hz): 0.39  
 Medie frequenze / Medium frequency (400-1250 Hz): 0.99  
 Alte frequenze / High frequency (1600-5000 Hz): 0.64

Freq. (Hz)	Risultato / Result
100	0.08
125	0.10
160	0.16
200	0.19
250	0.28
315	0.33
400	0.47
500	0.64
630	0.77
800	0.87
1000	0.89
1250	0.82
1600	0.68
2000	0.59
2500	0.49
3150	0.44
4000	0.48
5000	0.53

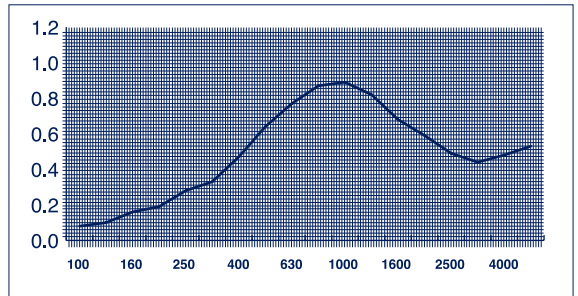
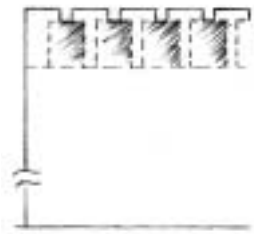

**Spazio vuoto / Free Space 40 mm senza lana di roccia / without Mineral Wool**

Basse frequenze / Low frequency (100-315 Hz): 0.19  
 Medie frequenze / Medium frequency (400-1250 Hz): 0.74  
 Alte frequenze / High frequency (1600-5000 Hz): 0.54

**TOPAKUSTIK 13/3: grado di fonoassorbenza secondo ISO 354**  
**TOPAKUSTIK 13/3: sound-deadening capacity according to ISO 354**

Materiale testato <i>Material tested</i>	tipologia / type 13/3 M - perforazione / drilling 12% tessuto / fabric SP 60 N	
Misurazione in camera riverberante  <i>Measurements in reverberation chamber</i>	riferimento / reference:  volume / volume: temperatura / temperature: umidità dell'aria / air humidity: superficie rivestita / area covered:	a)EMPA 03.05.1999 b) c) PTT 26.10.1996 a) 211m <sup>3</sup> b) e c) 214.3 m <sup>3</sup> a) 21° b) e c) 20° a) 52% b) e c) 55% a) 12m <sup>2</sup> b) e c) 3m <sup>2</sup>

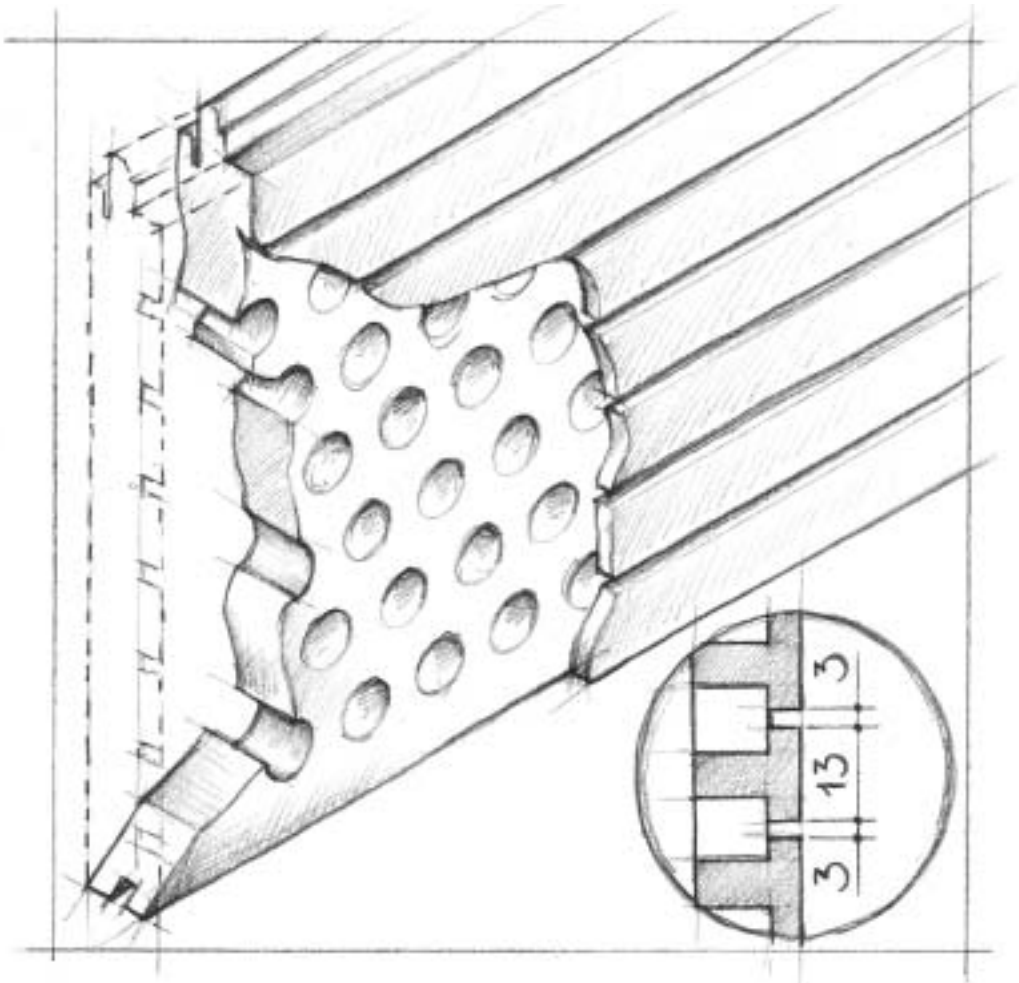

**tipologia 13/3 perforazione 6%**  
**type 13/3 drilling 6%**



VALORI MEDI DI FONOASSORBENZA / SOUND ABSORPTION AVERAGE VALUES

a)

Freq. (Hz)	Risultato / Result
100	0.29
125	0.34
160	0.45
200	0.63
250	0.83
315	1.01
400	0.98
500	0.90
630	0.90
800	0.88
1000	0.99
1250	0.90
1600	0.87
2000	0.72
2500	0.63
3150	0.60
4000	0.59
5000	0.52

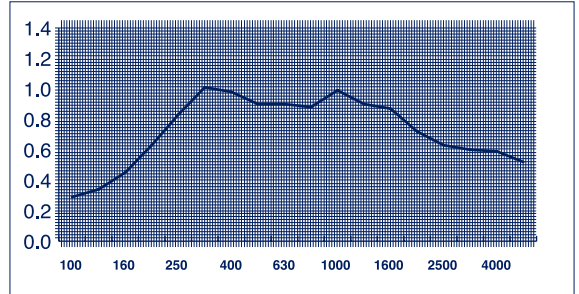
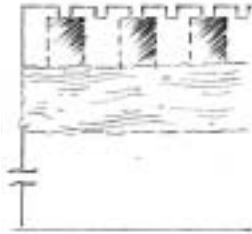

Spazio vuoto / Free Space 200 mm lana di roccia / Mineral Wool 30 mm

Basse frequenze / Low frequency (100-315 Hz): 0.59  
 Medie frequenze / Medium frequency (400-1250 Hz): 0.93  
 Alte frequenze / High frequency (1600-5000 Hz): 0.66

b)

Freq. (Hz)	Risultato / Result
100	0.06
125	0.16
160	0.31
200	0.41
250	0.51
315	0.73
400	1.01
500	1.14
630	1.23
800	1.12
1000	1.11
1250	0.88
1600	0.81
2000	0.77
2500	0.67
3150	0.67
4000	0.67
5000	0.57

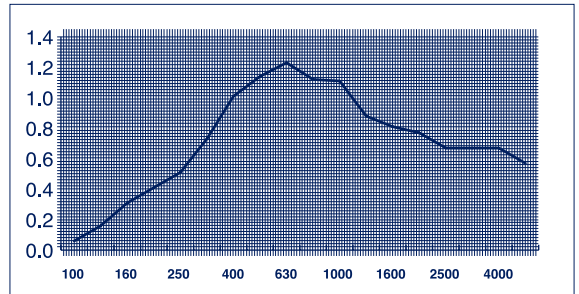
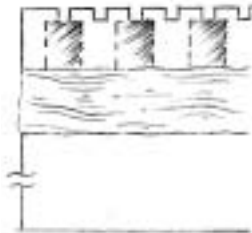

Spazio vuoto / Free Space 10 mm Isover / Isover 30 mm

Basse frequenze / Low frequency (100-315 Hz): 0.36  
 Medie frequenze / Medium frequency (400-1250 Hz): 1.08  
 Alte frequenze / High frequency (1600-5000 Hz): 0.69

c)

Freq. (Hz)	Risultato / Result
100	0.34
125	0.38
160	0.72
200	0.84
250	0.76
315	0.76
400	0.68
500	0.52
630	0.59
800	0.66
1000	0.64
1250	0.69
1600	0.66
2000	0.60
2500	0.60
3150	0.53
4000	0.57
5000	0.54

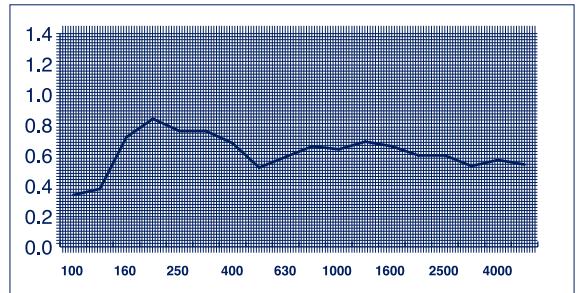
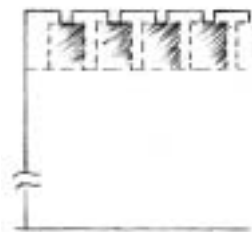

Spazio vuoto / Free Space 400 mm senza lana di roccia / without Mineral Wool

Basse frequenze / Low frequency (100-315 Hz): 0.63  
 Medie frequenze / Medium frequency (400-1250 Hz): 0.63  
 Alte frequenze / High frequency (1600-5000 Hz): 0.58

**TOPAKUSTIK 14/2: grado di fonoassorbenza secondo ISO 354**  
**TOPAKUSTIK 14/2: sound-deadening capacity according to ISO 354**

Materiale testato <i>Material tested</i>	tipologia / <i>type</i> 14/2 M - perforazione / <i>drilling</i> 7% tessuto / <i>fabric</i> SP 60 N	
Misurazione in camera riverberante <i>Measurements</i> <i>in reverberation chamber</i>	riferimento / <i>reference</i> : volume / <i>volume</i> : temperatura / <i>temperature</i> : umidità dell'aria / <i>air humidity</i> : superficie rivestita / <i>area covered</i> :	03.05.1999 214.3 m <sup>3</sup> 20° 55% 12m <sup>2</sup>

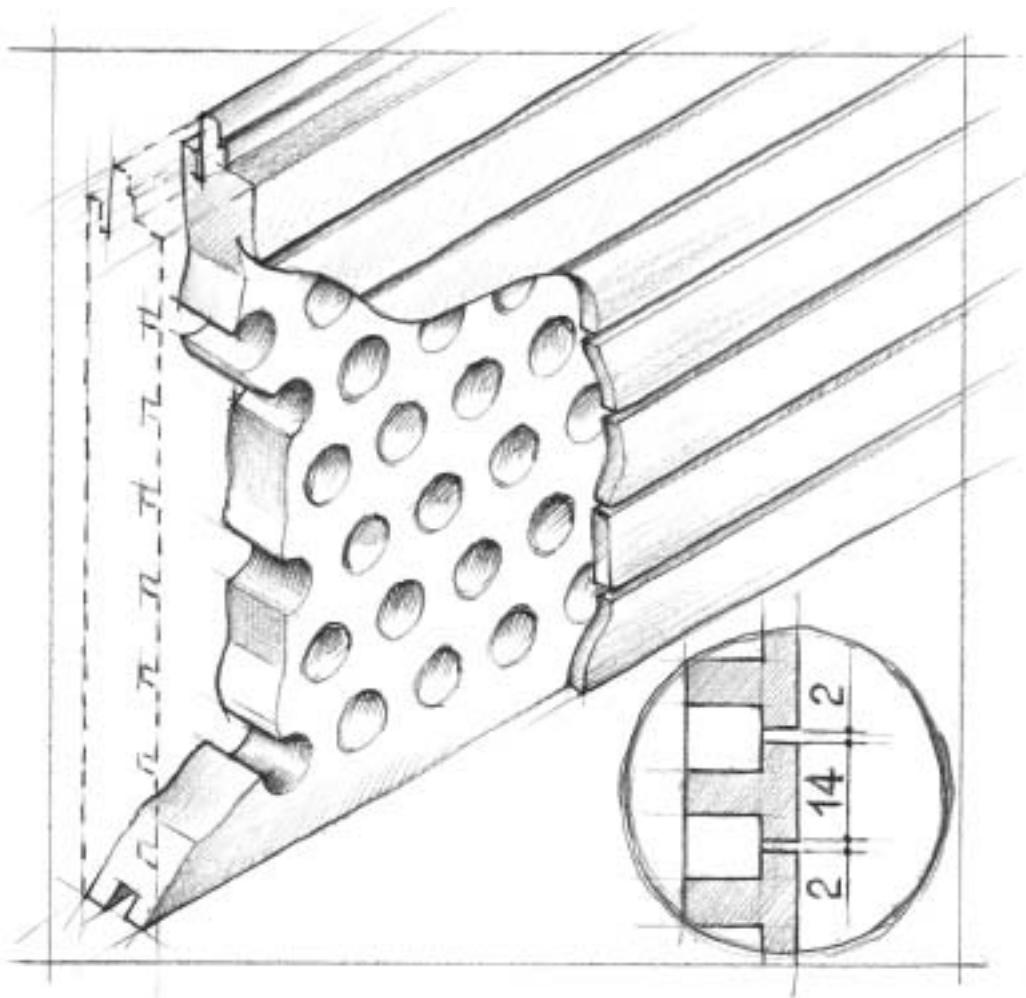

**tipologia 14/2 perforazione 7%**  
**type 14/2 drilling 7%**

**VALORI MEDI DI FONOASSORBENZA / SOUND ABSORPTION AVERAGE VALUES**

Freq. (Hz)	Risultato / Result
100	0.23
125	0.27
160	0.46
200	0.74
250	0.77
315	0.93
400	0.94
500	0.95
630	0.89
800	0.90
1000	0.94
1250	0.91
1600	0.88
2000	0.85
2500	0.75
3150	0.66
4000	0.60
5000	0.53

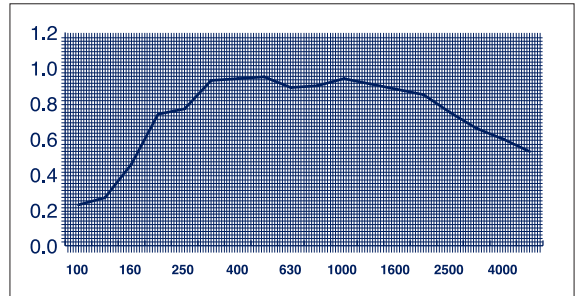
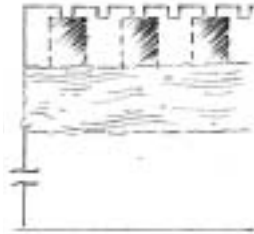

**Spazio vuoto / Free Space 170 mm lana di roccia / Mineral Wool 30 mm**

Basse frequenze / Low frequency (100-315 Hz): 0.57  
 Medie frequenze / Medium frequency (400-1250 Hz): 0.92  
 Alte frequenze / High frequency (1600-5000 Hz): 0.71

Freq. (Hz)	Risultato / Result
100	0.08
125	0.12
160	0.24
200	0.35
250	0.60
315	0.77
400	0.91
500	1.05
630	1.05
800	1.06
1000	1.03
1250	0.92
1600	0.87
2000	0.79
2500	0.72
3150	0.65
4000	0.61
5000	0.50

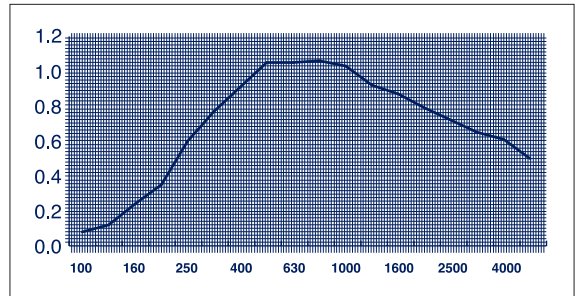
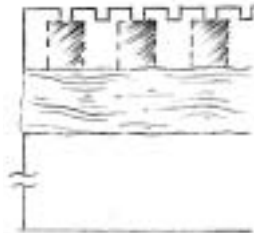

**Spazio libero / Free Space 10 mm lana di roccia / Mineral Wool 30 mm**

Basse frequenze / Low frequency (100-315 Hz): 0.36  
 Medie frequenze / Medium frequency (400-1250 Hz): 1.00  
 Alte frequenze / High frequency (1600-5000 Hz): 0.69

Freq. (Hz)	Risultato / Result
100	0.06
125	0.08
160	0.14
200	0.17
250	0.25
315	0.29
400	0.41
500	0.56
630	0.68
800	0.81
1000	0.87
1250	0.82
1600	0.70
2000	0.60
2500	0.51
3150	0.44
4000	0.50
5000	0.47

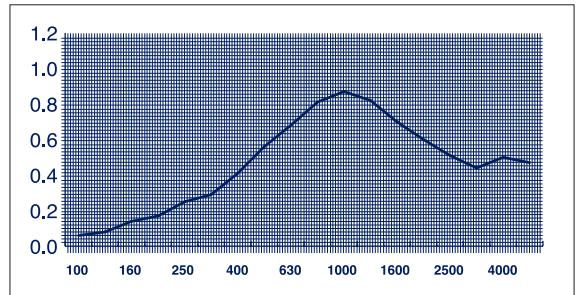
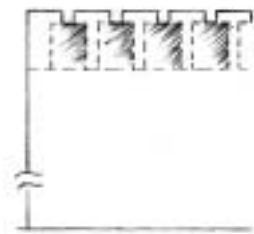

**Spazio libero / Free Space 40 mm senza lana di roccia / without Mineral Wool**

Basse frequenze / Low frequency (100-315 Hz): 0.17  
 Medie frequenze / Medium frequency (400-1250 Hz): 0.69  
 Alte frequenze / High frequency (1600-5000 Hz): 0.54

**TOPAKUSTIK 28/4: grado di fonoassorbenza secondo ISO 354**  
**TOPAKUSTIK 28/4: sound-deadening capacity according to ISO 354**

Materiale testato <i>Material tested</i>	tipologia / <i>type</i> 28/4 M - perforazione / <i>drilling</i> 7.5% tessuto / <i>fabric</i> SP 63 A	
Misurazione in camera riverberante <i>Measurements</i> <i>in reverberation chamber</i>	riferimento / <i>reference</i> : volume / <i>volume</i> : temperatura / <i>temperature</i> : umidità dell'aria / <i>air humidity</i> : superficie rivestita / <i>area covered</i> :	ITA 19.12.1994 218 m <sup>3</sup> 13° 80% 10m <sup>2</sup>

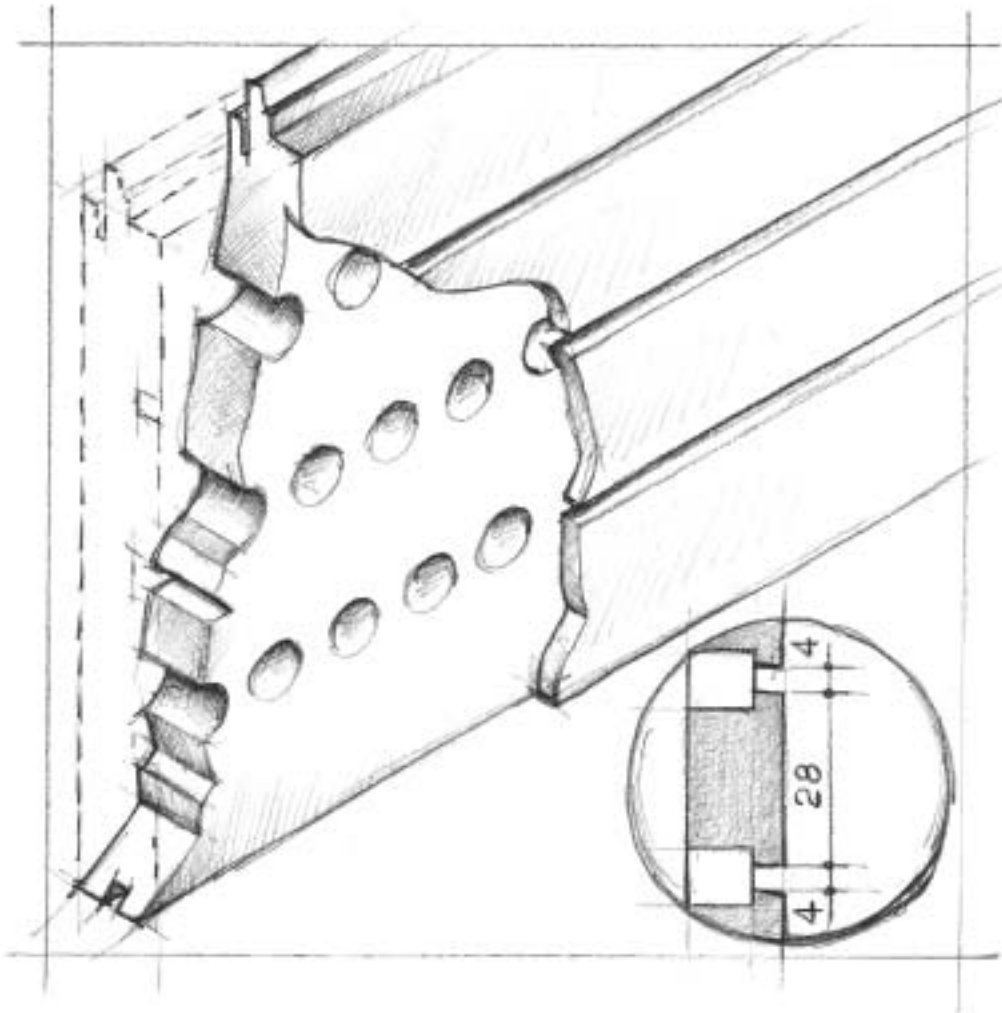

**tipologia 28/4 perforazione 7.5%**  
**type 28/4 drilling 7.5%**

VALORI MEDI DI FONOASSORBENZA / SOUND ABSORPTION AVERAGE VALUES

Freq. (Hz)	Risultato / Result
100	0.32
125	0.65
160	0.75
200	0.69
250	0.94
315	1.08
400	1.09
500	0.94
630	0.81
800	0.71
1000	0.73
1250	0.68
1600	0.59
2000	0.51
2500	0.45
3150	0.44
4000	0.43
5000	0.48

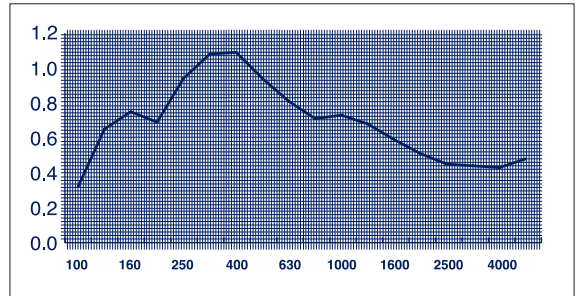
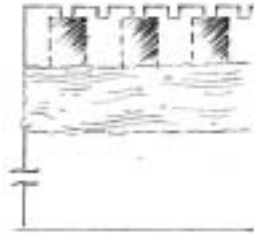

Spazio libero / Free Space 170 mm lana di roccia / Mineral Wool 30 mm

Basse frequenze / Low frequency (100-315 Hz): 0.74  
 Medie frequenze / Medium frequency (400-1250 Hz): 0.83  
 Alte frequenze / High frequency (1600-5000 Hz): 0.48

Freq. (Hz)	Risultato / Result
100	0.07
125	0.17
160	0.22
200	0.32
250	0.48
315	0.66
400	0.86
500	1.03
630	1.06
800	1.01
1000	0.88
1250	0.71
1600	0.56
2000	0.47
2500	0.44
3150	0.44
4000	0.41
5000	0.50

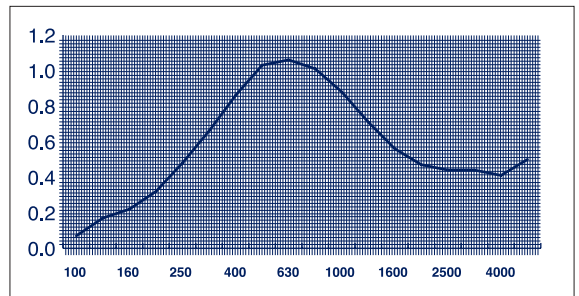
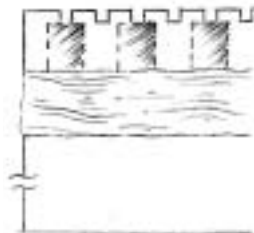

Spazio libero / Free Space 0 mm lana di roccia / Mineral Wool 30 mm

Basse frequenze / Low frequency (100-315 Hz): 0.32  
 Medie frequenze / Medium frequency (400-1250 Hz): 0.93  
 Alte frequenze / High frequency (1600-5000 Hz): 0.47

Freq. (Hz)	Risultato / Result
100	0.25
125	0.42
160	0.52
200	0.55
250	0.69
315	0.86
400	0.90
500	0.80
630	0.65
800	0.47
1000	0.43
1250	0.47
1600	0.37
2000	0.35
2500	0.34
3150	0.39
4000	0.40
5000	0.46

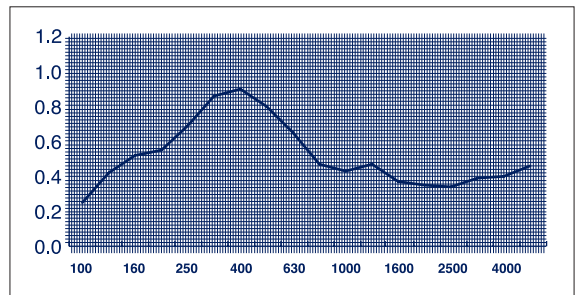
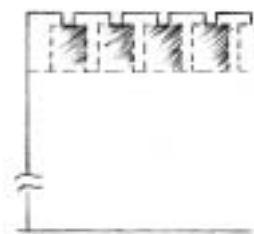

Spazio libero / Free Space 200 mm senza lana di roccia / without Mineral Wool

Basse frequenze / Low frequency (100-315 Hz): 0.55  
 Medie frequenze / Medium frequency (400-1250 Hz): 0.62  
 Alte frequenze / High frequency (1600-5000 Hz): 0.39





## **CONDIZIONI GENERALI D'USO / GENERAL CONDITIONS FOR USE**

### **Prima dell'installazione**

TOPAKUSTIK deve essere immagazzinato in ambiente chiuso e protetto dall'umidità.

### **Installazione**

Gli imballi delle lamelle TOPAKUSTIK devono essere aperti 48 ore prima della posa nei medesimi locali d'installazione in modo che il materiale raggiunga idonee condizioni di equilibrio con l'ambiente.

TOPAKUSTIK deve essere installato in:  
locali con temperatura minima di 15°C  
locali con umidità ambientale compresa tra 40% e 60%  
locali condizionati almeno 24 ore prima dell'installazione

### ***Prior to installation***

*TOPAKUSTIK must be stored indoors and protected against humidity.*

### ***Installation***

*The TOPAKUSTIK packs must be opened 48 hours before installation, in the installation location, to allow the material to stabilise itself at ambient conditions.*

*TOPAKUSTIK must be installed in:  
environments with a minimum temperature of 15°C  
environments with humidity between 40% and 60%  
environments which have been conditioned for at least 24 hours prior to installation*

---

## RIVESTIMENTO A PARETE / WALL CLADDING

### Sotto struttura - materiali

profilo in metallo con sezione a  $\Omega$ , dimensioni 3000x18x26 mm  
accessori di fissaggio costituiti da vite autoforante o vite più tassello, a seconda del tipo di supporto  
piastrine di aggancio a farfalla per ancoraggio su profilo  $\Omega$   
materassino isolante in fibra minerale

### Support structure - materials

*metal omega rail, dimensions 3000x18x26 mm*  
*fixing accessories consisting of self-tapping screws or screws plus expansion fixing, depending on the type of support*  
*butterfly plates for anchoring to omega rail*  
*mineral fibre insulating mat*

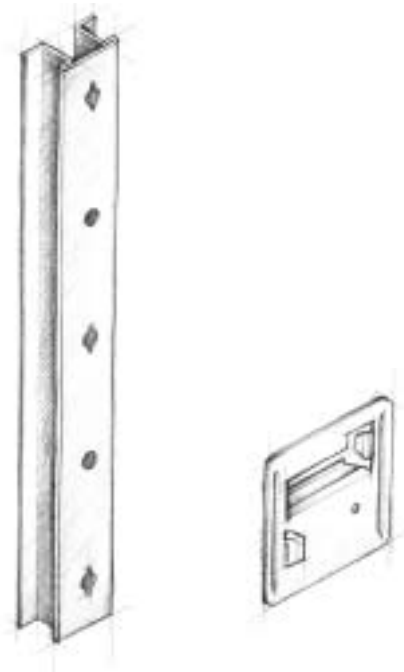

**RIVESTIMENTO A PARETE / WALL CLADDING**

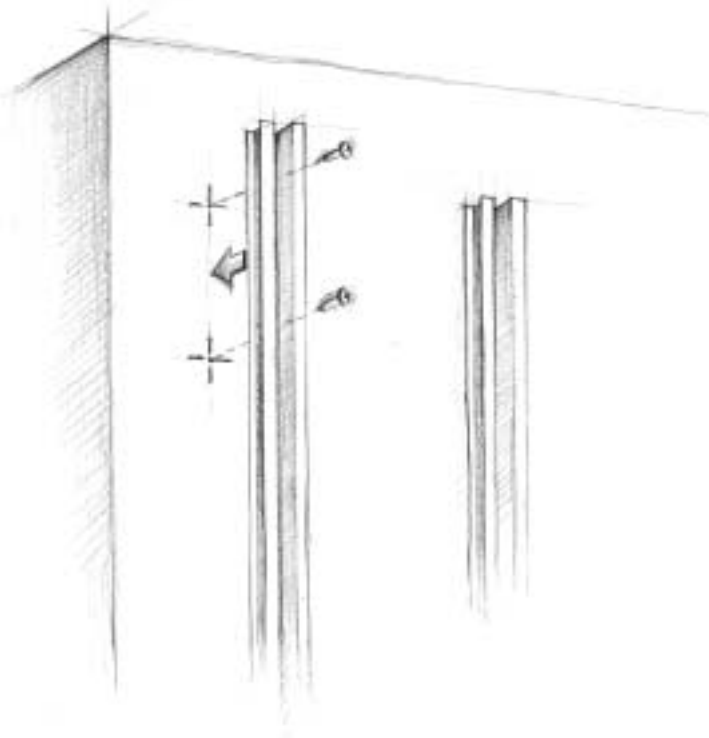

**ISTRUZIONE DI POSA / INSTALLATION INSTRUCTIONS**

**ATTENZIONE**

La distanza consigliata fra i profili  $\Omega$  di sostegno è di circa 600 mm.

Fissare a parete la struttura in metallo in senso perpendicolare a come si intende poi montare il TOPAKUSTIK.

**ATTENTION**

*The recommended distance between omega support rails is about 600 mm.*

*Secure the metal structure to the wall at right angles to the direction in which the TOPAKUSTIK panels are to be mounted.*

Disporre i pannelli in fibra minerale tra i profili metallici.

*Lay the mineral fibre panels between the metal rails.*

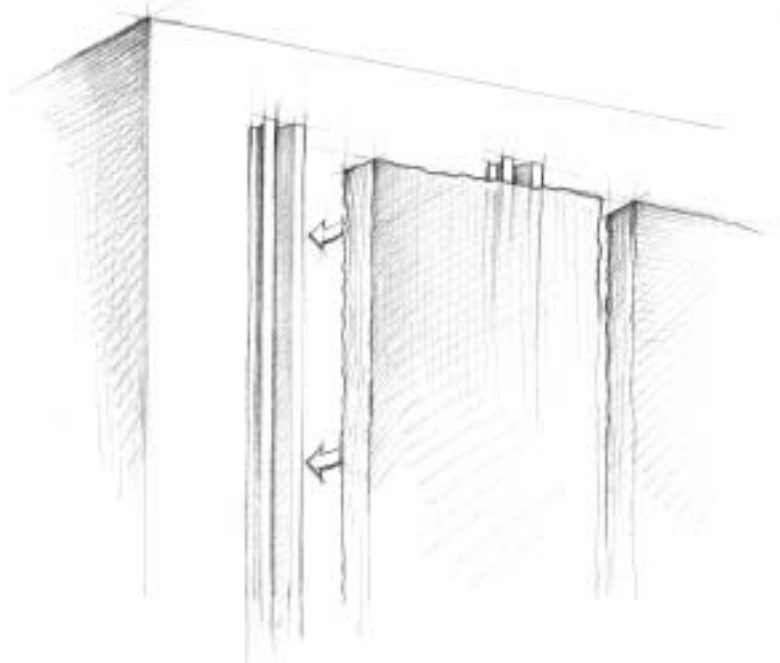

**RIVESTIMENTO A PARETE/ WALL CLADDING**

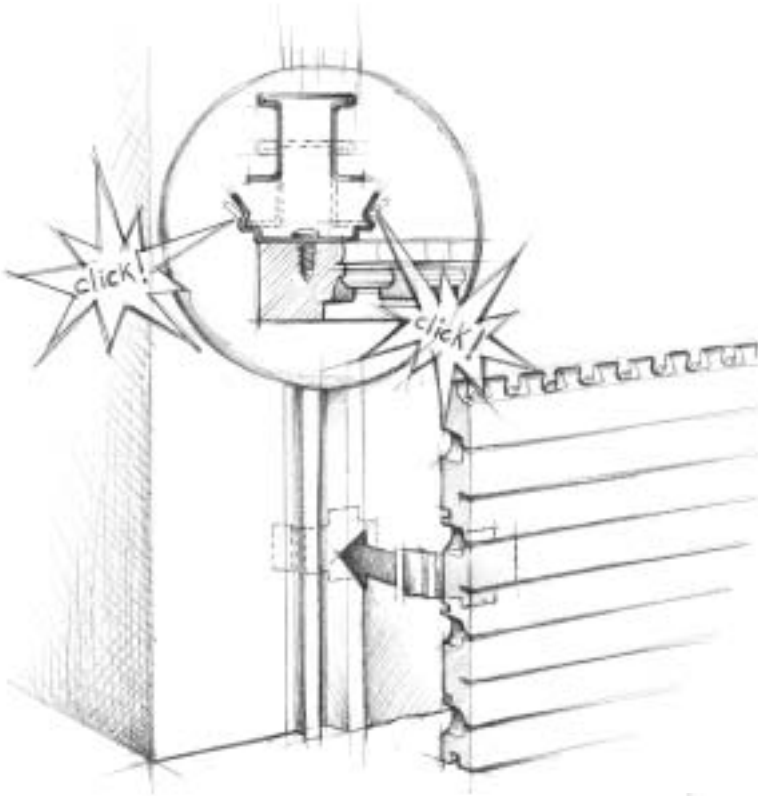

Per TOPAKUSTIK con fugatura orizzontale, posizionare la prima lamella con il lato femmina verso il pavimento e fissarla con le apposite mollette di partenza, successivamente inserire le piastrine a farfalla per l'ancoraggio del lato maschio.

*For TOPAKUSTIK with horizontal joints, place the first strip with the female side towards the floor and secure it with the special starter clips, then insert the butterfly plates to anchor the male side.*

Posizionare quindi le lamelle successive sovrapponendole alla prima e fissandole allo stesso modo.

*Then position subsequent strips above the first strip, securing them in the same way.*

Nel caso di TOPAKUSTIK con fugatura verticale, iniziare da un lato eseguendo in successione le stesse operazioni.

*For TOPAKUSTIK with vertical joints, start from one side and proceed in the same way.*

Si consiglia di fissare almeno una piastrina a farfalla ogni 4 mediante vite.

*It is suggested to insert one screw every 4 butterfly plates at least.*

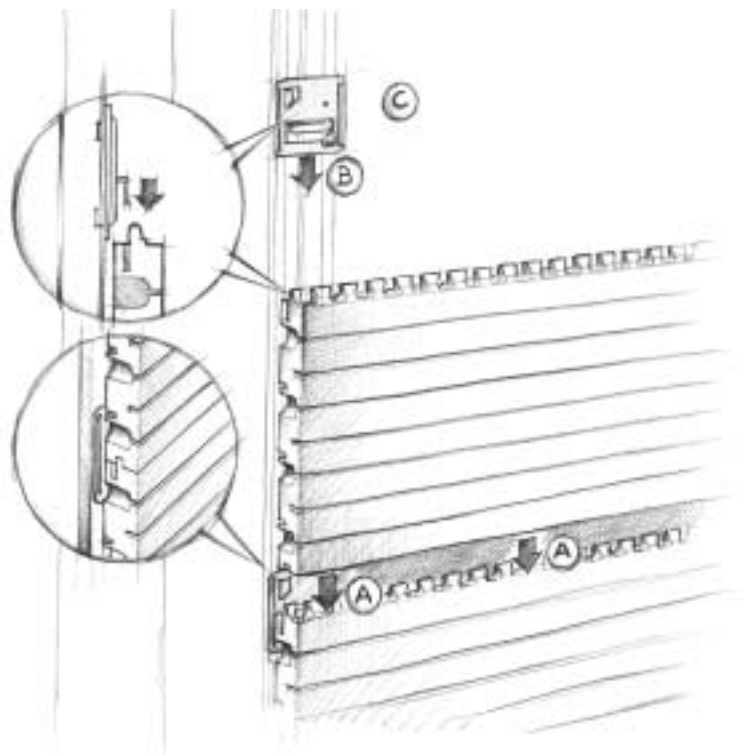



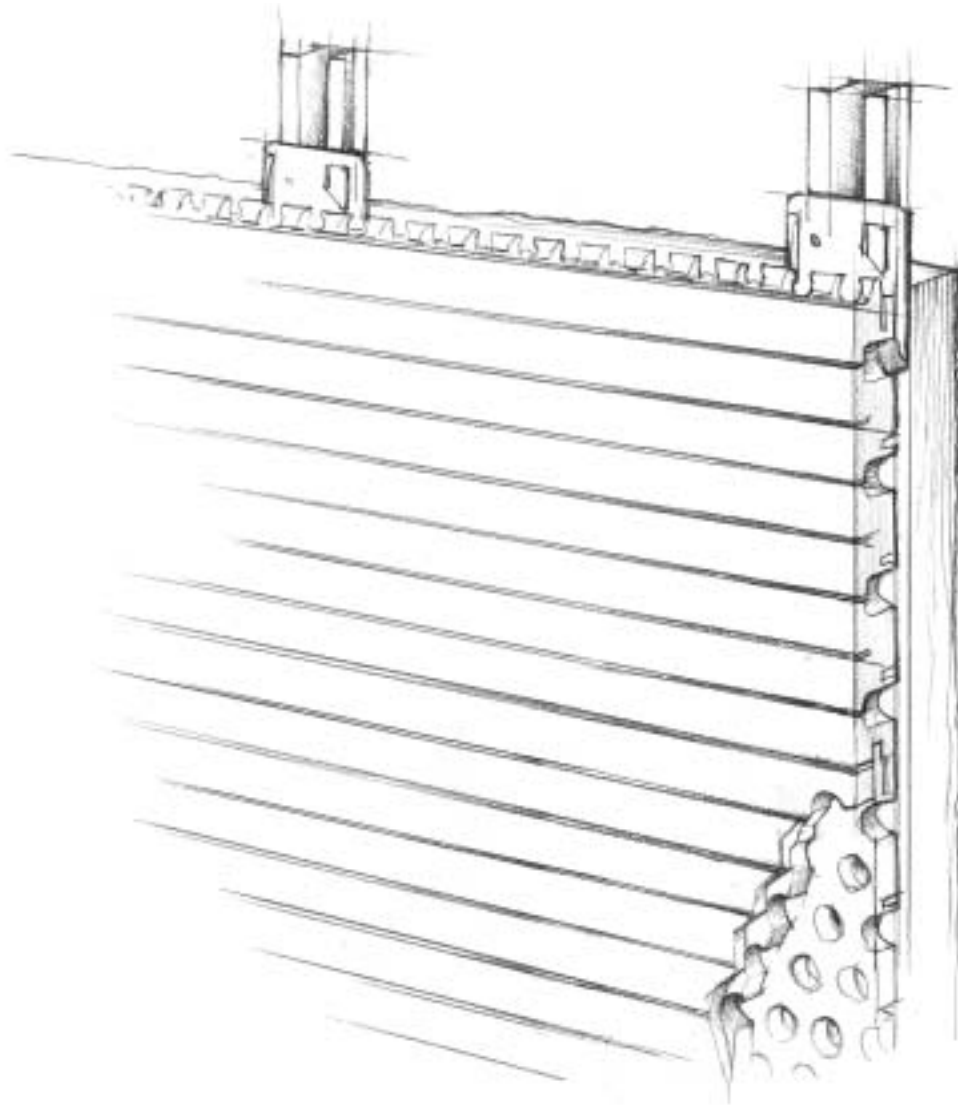

Nel caso di accostamento delle lamelle TOPAKUSTIK in lunghezza si possono adottare diverse soluzioni: lasciare uno spazio libero tra le due lamelle uguale alla fresatura; accostare le teste fissandole fra loro; utilizzare gli appositi giunti di dilatazione (vedi accessori).

Nella scelta della soluzione da adottare è importante tenere conto che la lunghezza delle lamelle TOPAKUSTIK può variare a fronte di diverse condizioni di umidità dell'ambiente.

*When TOPAKUSTIK strips are laid end to end, various solutions are possible: leave a gap between the two strips, the same width as the milling; butt-join the ends and secure them together using the special expansion joints (see accessories).*

*When choosing which solution to adopt, it is important to take into account that the length of the TOPAKUSTIK strips can vary according to differing environmental humidity conditions.*

**RIVESTIMENTO PER CONTROSOFFITTO / FALSE CEILING APPLICATION****Sotto struttura - materiali**

sistema di pendini in metallo diam. 4 mm per il fissaggio del profilo  $\Omega$  a soffitto  
staffa aggancio pendino  
profilo in metallo con sezione a  $\Omega$ , dimensioni 3000x18x26 mm  
piastrine di aggancio a farfalla per ancoraggio su profilo  $\Omega$   
materassino isolante in fibra minerale

**Support structure - materials**

4 mm diam. hanger system for fixing the omega rail to the ceiling  
hanger attachment bracket  
metal omega rail, dimensions 3000x18x26 mm  
butterfly plates for anchoring to omega rail  
mineral fibre insulating mat

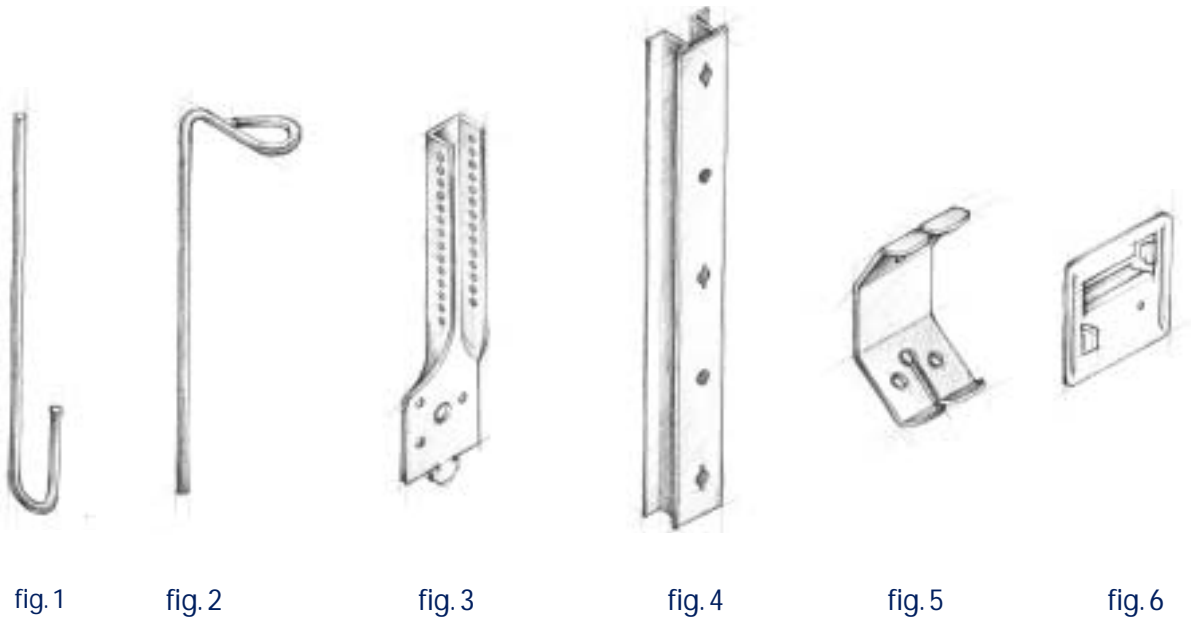

fig. 1

fig. 2

fig. 3

fig. 4

fig. 5

fig. 6

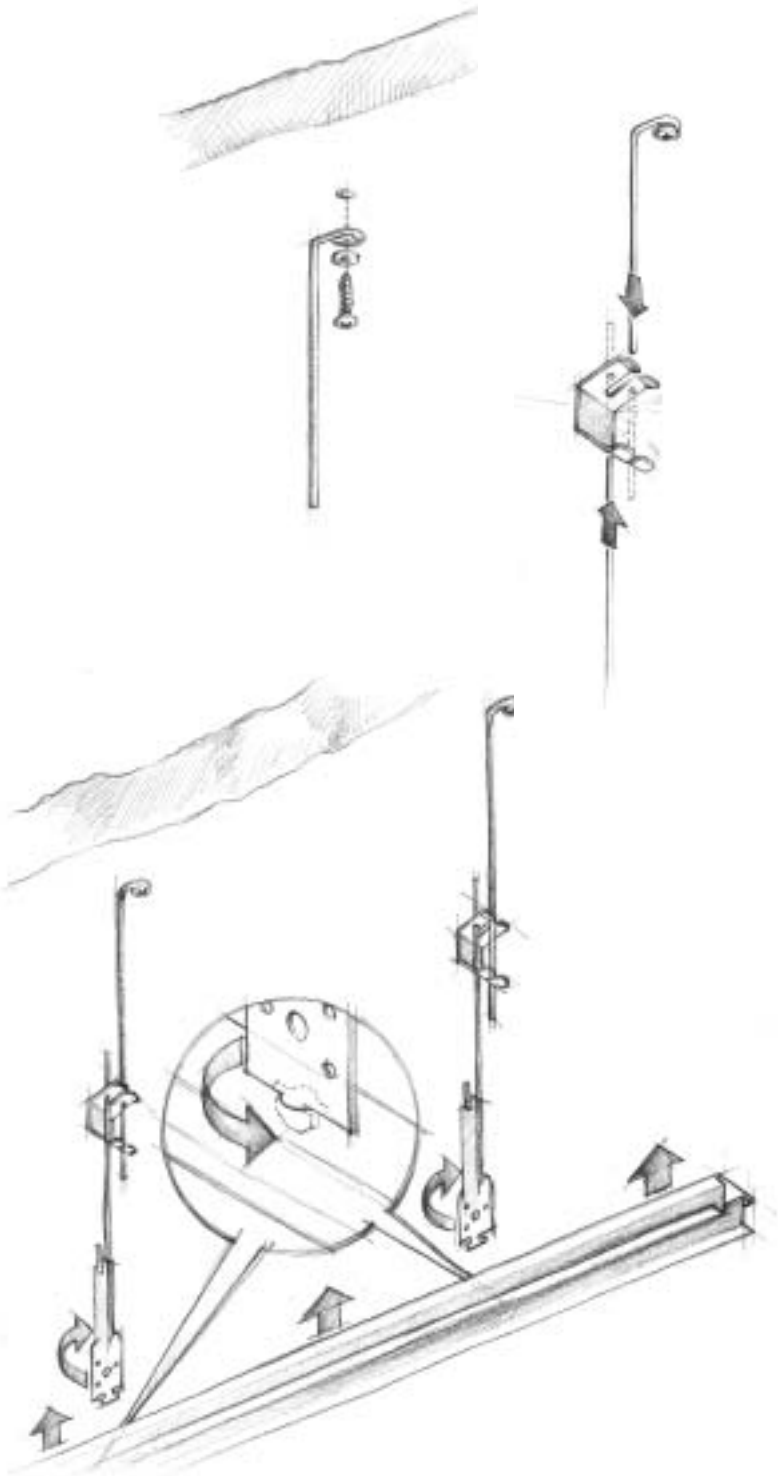
**RIVESTIMENTO PER CONTROSOFFITTO / FALSE CEILING APPLICATION**

Realizzare la sottostruttura metallica di supporto montando i profili metallici, mediante appositi pendini, all'altezza necessaria da terra. I profili metallici a  $\Omega$  devono essere montati perpendicolarmente alla direzione delle lamelle TOPAKUSTIK.

*Build the metal support structure by fitting the metal rails, using the special hangers, at the required height from the ground. The omega rails must be fitted at right angles to the direction of the TOPAKUSTIK strips.*

**RIVESTIMENTO PER CONTROSOFFITTO / FALSE CEILING APPLICATION**

Montare il profilo perimetrale prevedendo uno spazio libero di 18 mm tra l'appoggio orizzontale del profilo e la sottostruttura di supporto.

*Fit the perimeter rail leaving a gap of 18 mm between the rail's horizontal seat and the support structure.*

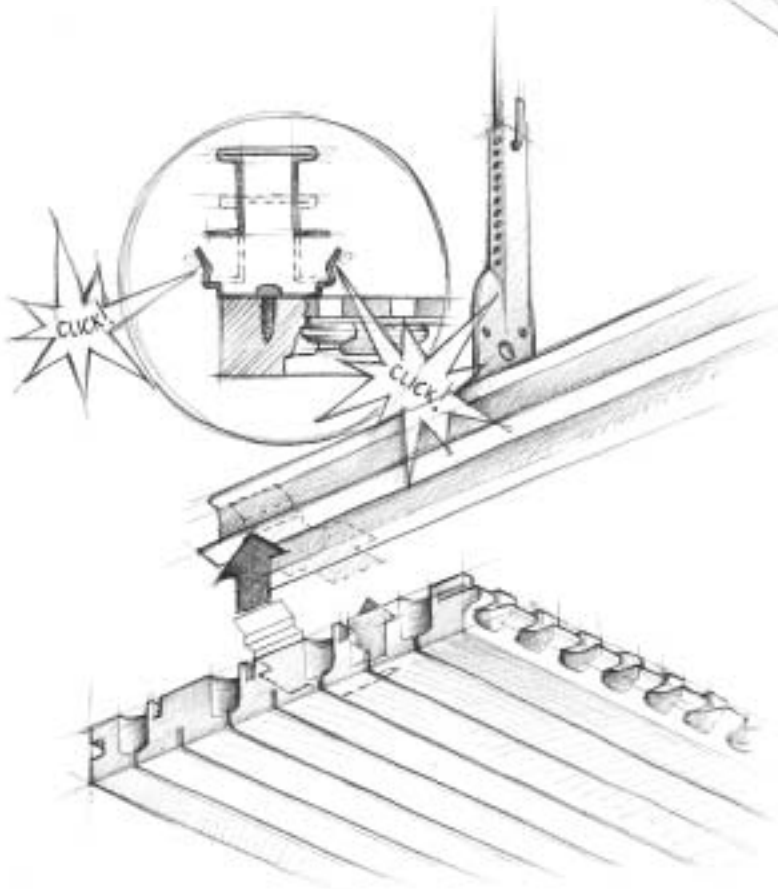
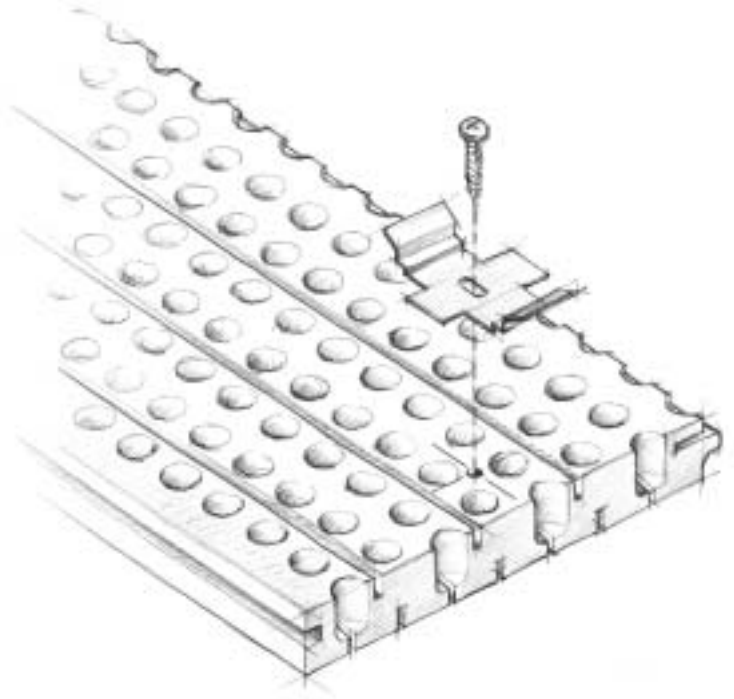

Posare il lato femmina della prima lamella TOPAKUSTIK in appoggio sul profilo perimetrale e fissarla al profilo Ω con la molletta di partenza .

Successivamente inserire le piastrine a farfalla per l'ancoraggio del lato maschio.

*Place the female side of the first TOPAKUSTIK strip up against the perimeter rail and secure it to the omega rail using the starter clip.*

*Then insert the butterfly plates to anchor the male side.*

**RIVESTIMENTO PER CONTROSOFFITTO / FALSE CEILING APPLICATION**



Accostare la seconda lamelle alla prima e quindi le successive ripetendo l'operazione di ancoraggio con le piastrine a farfalla fino alla completa posa.

*Place the second strip against the first and then continue with the subsequent strips, repeating the anchoring operation using butterfly plates until installation has been completed.*

È consigliabile fissare con vite autofilettante le piastrine a farfalla al profilo Ω della sottostruttura.

*It is recommended that the butterfly plates be secured to the support structure omega rail by means of self tapping screws.*

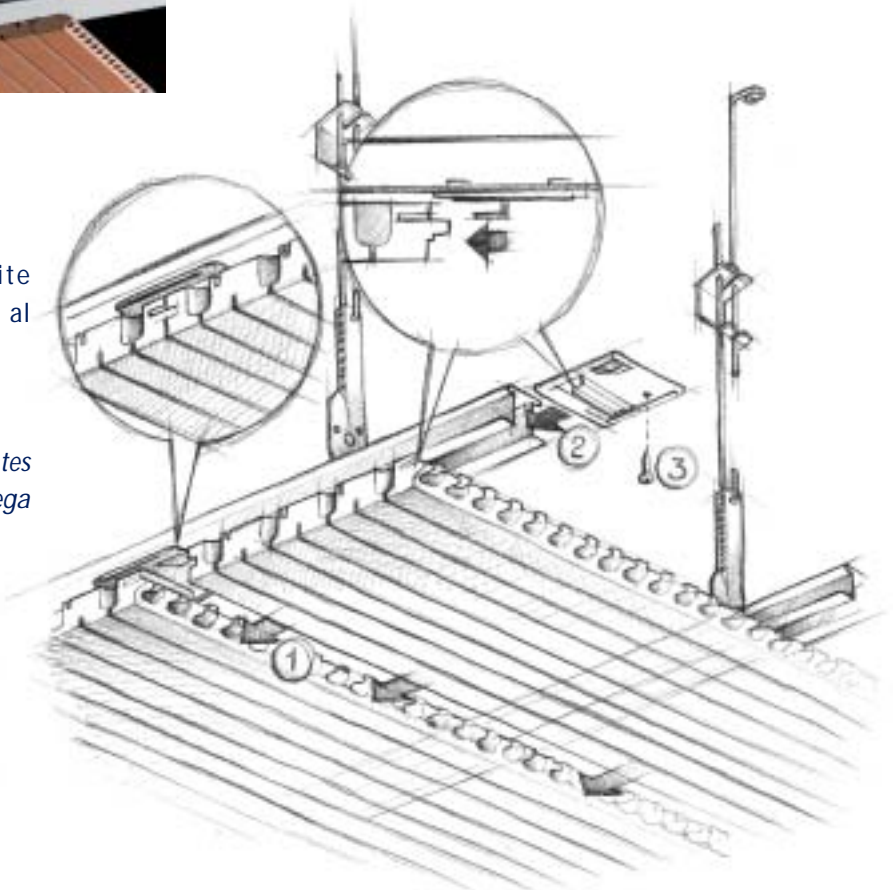



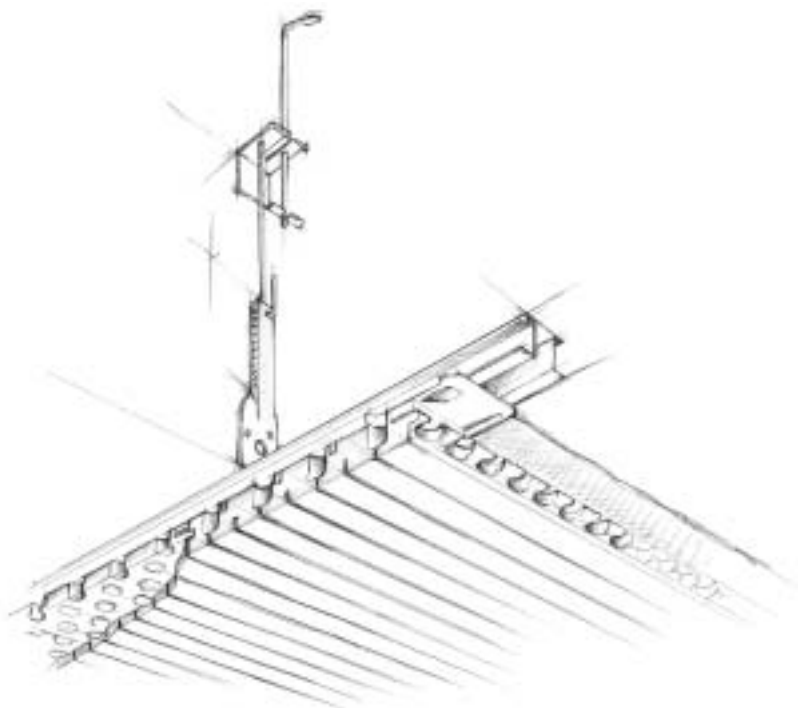

## ATTENZIONE / ATTENTION

La distanza consigliata tra i profili metallici di sostegno e dei pendini o cavi tra di loro è di circa 60 cm.

*The recommended distance between the metal support rails and the hangers or cables is about 60 cm.*

Nel caso di accostamento di lamelle TOPAKUSTIK in lunghezza (ambienti di misura superiore alla lamella) lasciare uno spazio libero tra le due lamelle pari alla fugatura delle lamelle stesse (circa 3 mm).

*When TOPAKUSTIK strips are placed end to end (rooms larger than the strip length) leave a gap between the two strips equivalent to the spacing between the strips themselves (about 3 mm).*

Nel caso di accostamento delle lamelle TOPAKUSTIK in lunghezza si possono adottare diverse soluzioni: lasciare uno spazio libero tra le due lamelle uguale alla fresatura; accostare le teste fissandole fra loro; utilizzare gli appositi giunti di dilatazione (vedi accessori).

Nella scelta della soluzione da adottare è importante tenere conto che la lunghezza delle lamelle TOPAKUSTIK può variare a fronte di diverse condizioni di umidità dell'ambiente.

*When TOPAKUSTIK strips are laid end to end, various solutions are possible: leave a gap between the two strips, the same width as the milling; butt-join the ends and secure them together, using the special expansion joints (see accessories).*

*When choosing which solution to adopt, it is important to take into account that the length of the TOPAKUSTIK strips can vary according to differing environmental humidity conditions.*

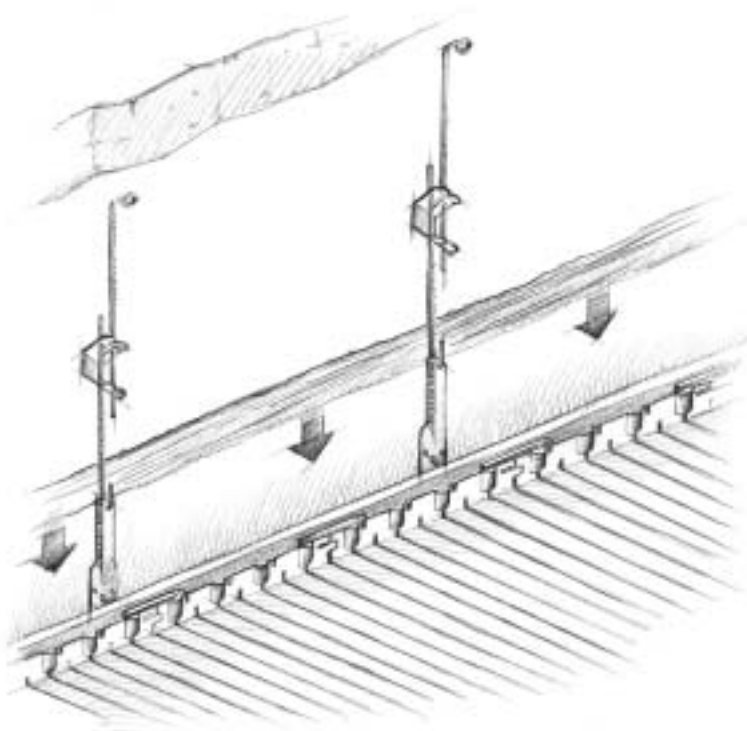



**ACCESSORI DI FINITURA / FINISHING ACCESSORIES**

**Profilo perimetrale a L e doppia L / L-shaped and double L-shaped perimeter rail**

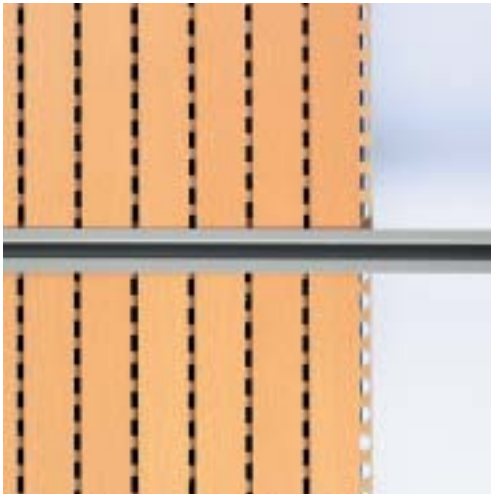

profilo di giunzione  
*joint rail*

profilo a "L"  
*L-shaped rail*

profilo a doppia "L"  
*double L-shaped rail*



## RIVESTIMENTO PER CONTROSOFFITTO / FALSE CEILING CLADDING

### Portello di ispezione / *Inspection Door*

Può essere realizzato al momento del montaggio, dove necessario, utilizzando l'apposito set composto da:  
*Can be created at the time of assembly, where necessary, using the special kit comprising:*

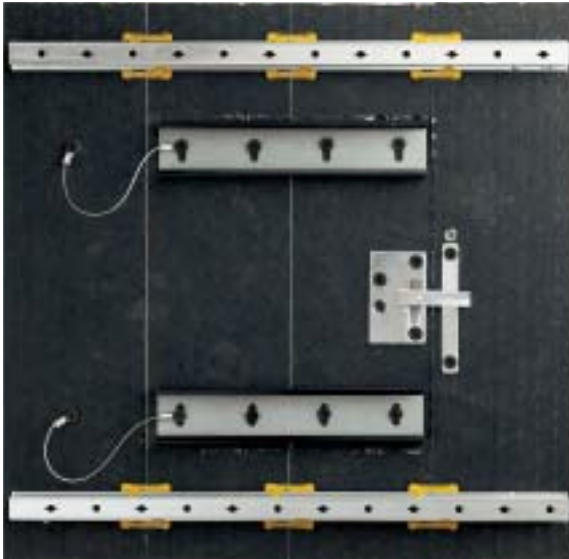

chiavistello girevole  
piastra di riscontro  
cavetti con viti ad anello  
piastra di fissaggio regolabile in altezza 2.5 mm circa

*pivoting latch  
striker plate  
cables with ring bolts  
fixing plate, with height adjustment of about 2.5 mm.*









**ANNOTAZIONI / NOTES**



**TOPAKUSTIK** N'H Akustik+Design AG - CH-6078  
Lungern Ph. + 41 679 70 80 Fax +41 679 70 59  
e-mail: [nholzbau@nh-lungern.ch](mailto:nholzbau@nh-lungern.ch) [www.nhlungern.ch](http://www.nhlungern.ch)

**Patt** Srl Via Udine 40 33040 Attimis / Udine  
Italy Ph. + 39 0432 796411 Fax + 39 0432 796400  
e-mail: [TOPAKUSTIK@patt-srl.it](mailto:TOPAKUSTIK@patt-srl.it)

TOP)A)K)U)S)T)I)K)<sup>®</sup>  
**patt**